



trueheat

GAS COOKING EQUIPMENT

RC SERIES



Distributed by

COMCATER
- foodservice equipment

Comcater Pty Ltd
156 Swann Drive,
Derrimut VIC 3026
Tel: +61 (0)3 8369 4600
Fax: +61 (0)3 8369 4600
www.comcater.com.au



RCP4
Gas Pasta Cooker

INSTALLATION & OPERATION MANUAL

CONGRATULATIONS!

Thank you for choosing Trueheat.

This product has been specifically designed by Comcater to meet a wide range of applications and represents the best quality and highest value equipment.

Please read the instruction manual carefully to ensure the safe and reliable operation and performance of your equipment.

Should you require service, you will be supported by Comcater's trained and qualified service network.

COMCATER AUSTRALIA

www.comcater.com.au

National Head Office

156 Swann Drive, Derrimut, VIC 3026

Phone: 03 8369 4600

Fax: 03 8369 4699

Email: sales@comcater.com.au

Technical Services Group

Phone: 1800 810 161

Fax: 03 8369 4696

Email:

Equipment Servicing (24/7)

service@comcater.com.au

Equipment Spare Parts

spares@comcater.com.au

Technical Support

techsupport@comcater.com.au

BURNS & FERRALL LTD NEW ZEALAND

www.burnsferrall.co.nz

Support Office

12 Reg Savory Place , East Auckland

Po Box 13140, Onehunga Auckland 1643 New Zealand

Phone: 09 633 0900

Email: sales@burnsferrall.co.nz

Technical Services Group

Phone: 0800 178 349

Email:

Equipment Servicing (24/7)

service@burnsferrall.co.nz

Equipment Spare Parts

spares@burnsferrall.co.nz

Technical Support

service@burnsferrall.co.nz

Comcater QR Codes



Comcater Website



Log a Service Call



Online Spare Parts Store

TABLE OF CONTENTS



INTRODUCTION	
Warranty.....	4
Date Plate Location	4
WARNINGS	5
GENERAL INFORMATION	6
SPECIFICATIONS	
Dimensions, Weight & Installation Drawings.....	7
Accessories & Optional Accessories.....	7
Gas Configuration.....	8
INSTALLATION	
Gas Connection	11
Installation Clearances	11
Levelling.....	11
CONVERSION INSTRUCTIONS	12
COMMISSIONING / BURNER ADJUSTMENT	
Leak Test	12
Test Point Pressure	12
Pilot Adjustment	12
Target Adjustment	12
OPERATION	
First Time Use	13
Daily Operation	13
MAINTENANCE	
Daily Cleaning	14
Recommended Service Plan	15
TROUBLESHOOTING	
Burner will not light	16
Pilot not lighting	16

INTRODUCTION



GENERAL

The Trueheat RC Series is designed for commercial catering purposes only and incorporates a wide range of design features. It is designed to deliver high-end performance to fulfill the busy demands within a commercial kitchen. It is available in various appliances and configurations including:

Ranges with open burners, griddles with oven or as Counter-Top unit.

Broilers, salamanders, pasta cookers and deep fryers.

This versatility will satisfy a wide range of customer needs.

WARRANTY

12 months replacement of parts including labour, for goods found to be faulty due to defective materials, manufacture and/or workmanship. This warranty is void if installation, operation and/or maintenance of the equipment are not in accordance with manufacturer's instructions and recommendations.

Unauthorised modifications to the equipment will void the warranty and product certification.

All warranty work will be undertaken in normal working hours from Monday – Friday 8:00am to 4:00pm

Warranty does not extend to:

Damages caused in shipment

Damage as a result of incorrect installation

Damage as a result of incorrect operation

Damages caused by Unauthorised service and use of non-original parts

Gas supply issues to the equipment

Calibration of thermostats after 90 days

Failure resulting from improper maintenance

Failure as a result of tampering with, removal of, or changing any pre-set control or safety device

After hours Service - **Penalty rates apply for afterhours service.**

Conditions as defined in Comcater terms and condition of sale, a copy of Comcater's terms and conditions of sale can be found at www.comcater.com.au/terms







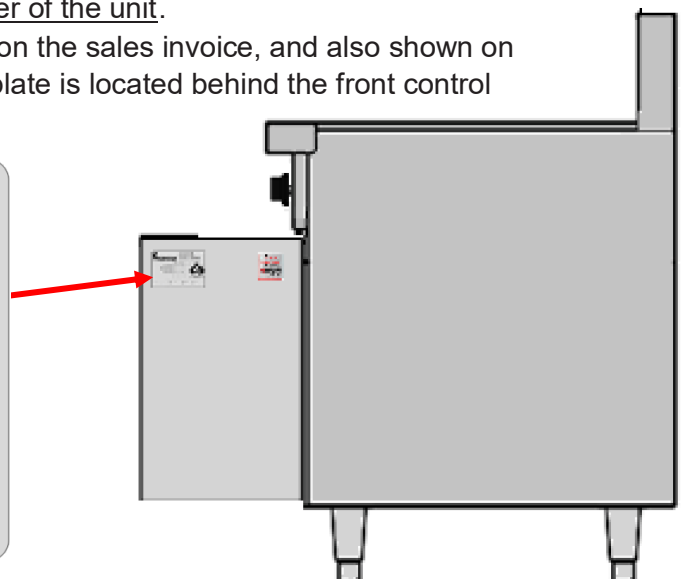
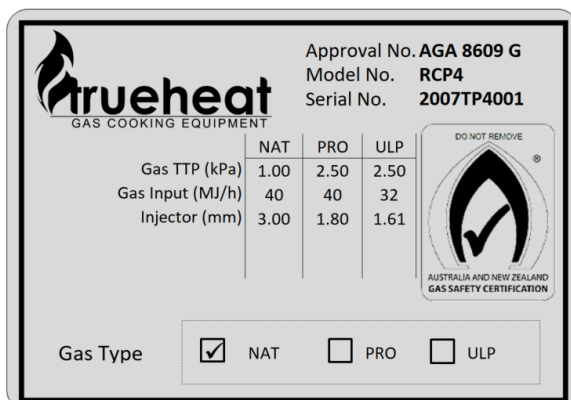

For all warranty work, authorized service, genuine and authorized spare parts, please contact Comcater Service 1800 810 161.

Please ensure you quote the Model and Serial Number of the unit.

The Model and Serial Number of the unit is recorded on the sales invoice, and also shown on the top right side of the front control panel. The data plate is located behind the front control panel.



WARNINGS

	<p>IMPROPER INSTALLATION, ADJUSTMENT, ALTERATION, SERVICE OR MAINTENANCE CAN CAUSE INJURY OR DEATH. THE INSTRUCTION MANUAL MUST BE READ CAREFULLY BEFORE INSTALLING, OPERATING OR SERVICING THIS EQUIPMENT.</p>
	<p>TO BE INSTALLED ONLY BY AN AUTHORISED PERSON IN ACCORDANCE WITH AS/NZS 5601.1, LOCAL AUTHORITY, GAS, ELECTRICITY, ANY APPLICABLE STATUTORY REGULATIONS AND MANUFACTURER REQUIREMENTS.</p>
	<p>THIS EQUIPMENT IS DESIGNED FOR COMMERCIAL CATERING PURPOSES AND WILL GENERATE SIGNIFICANT HEAT. HOT SURFACES WILL CAUSE BURNS. A HAZARD AND RISK ASSESSMENT MUST BE UNDERTAKEN BY OWNERS AND ALL OPERATORS MADE AWARE OF THESE.</p>
	<p>DO NOT STORE OR USE FLAMMABLE LIQUIDS NEAR THIS APPLIANCE.</p>
	<p>DO NOT SPRAY AEROSOLS NEAR THIS APPLIANCE WHILE IT IS IN OPERATION.</p>
	<p>INSTALLATION CLEARANCES AS SPECIFIED MUST BE OBSERVED.</p>
	<p>IF YOU SMELL GAS, TURN THE UNIT OFF AND THE MAIN GAS SUPPLY VALVE TO THE UNIT. CONTACT YOUR GAS SUPPLIER OR AN AUTHORISED PERSON.</p>
	<p>BEFORE TURNING ON THE MAIN GAS SUPPLY, CHECK THE UNIT TO BE CERTAIN THAT ALL THE VALVES ARE IN THE “OFF” POSITION.</p>

GENERAL INFORMATION



INSPECTION

Please inspect the unit on receipt. If the unit is damaged, contact the carrier immediately and file a damage claim with them. Save all packing materials when filing a claim. Freight damage claims are the responsibility of the purchaser and are not covered under warranty.

OPERATOR MANUAL

This manual contains important information for your safety and the installation, operation, maintenance and service of this equipment. Please read the manual carefully and ensure all operators of the equipment are aware of the contents and safety requirements. You must also assess all hazards and risks associated with the operation of the equipment in your environment and advise all operators of these.

INSTALLATION

This equipment must be installed by an authorized person in accordance with AS/NZS 5601.1, local authority, gas, electricity, any applicable statutory regulations and manufacturer requirements.

GAS CONNECTION

The appliance must be connected by an authorized person to the gas type specified on the unit. The gas type is shown adjacent to the rear gas connection point and on the data plate. Connect to and use only the correct type of gas.

GAS PRESSURE

The authorized person installing this equipment must ensure that the gas operating pressure is the same as shown on the rating plate and that there is sufficient gas volume for the appliance to operator correctly.

COMMISSIONING

The authorized person installing this equipment must commission the equipment in accordance with AS/NZS 5601.1 - gas leakage, operational checking, adjustments and instructing the owner on use of the equipment are prescribed requirements.

SPECIFICATIONS



DIMENSIONS, & INSTALLATION DRAWINGS, OPTIONAL ACCESSORIES

The following tables and drawings provide all dimension, weight and optional accessories.

DIMENSIONS	
Width (mm)	400
Depth (mm)	803
Height (mm)	1135

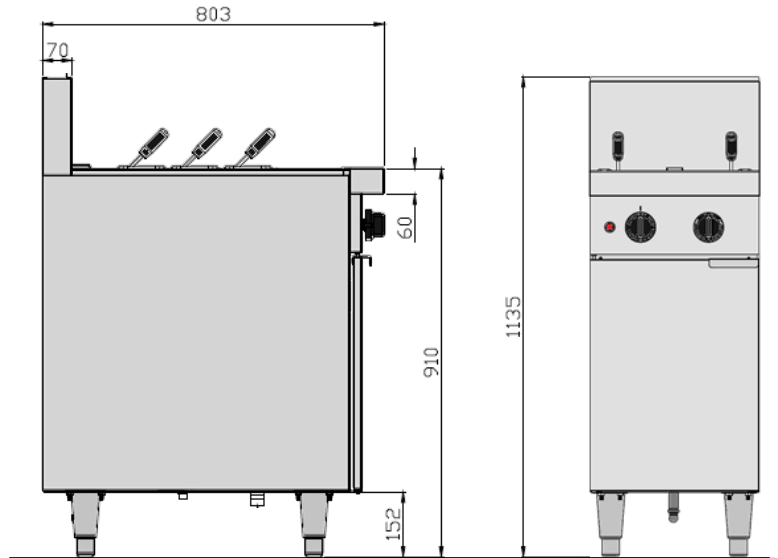



OPTIONAL ACCESSORIES

IMAGE	PART NO.	DESCRIPTION	*QTY
	S45069	Additional Basket Set with Wireframe	1
	B21273	Medium Basket 280L X 145W X 180H	1
	S35041	Noodle Basket Set with Stainless Steel Frame	1
	8100357	Front Castors Swivel with brake	2
	8100378	Rear Castors Fixed without brake	2
	COM-WF0116	1500mm SS braided water hose 3/4" female & 1/2" female	1
	432018-900HK	900mm 3/4" flexible gas hose with quick connect fittings & restraint	1
	432018-1200HK	1200mm 3/4" flexible gas hose with quick connect fittings & restraint	

*QTY = Quantity required per unit.

SPECIFICATIONS (cont'd)

GAS CONFIGURATION

	TO BE COMPLETED BY AN AUTHORISED PERSON.
	ONLY CONNECT THE APPLIANCE TO THE GAS TYPE IT HAS BEEN CONFIGURED FOR. THE GAS TYPE IS SPECIFIED ON THE DATA PLATE AND AT THE REAR OF THE APPLIANCE.

Description	NATURAL GAS	PROPANE GAS	UNIVERSAL LPG
Minimum Inlet Pressure	1.13 kPa	2.75 kPa	2.75 kPa
Test Point Pressure	1.00 kPa	2.50 kPa	2.50 kPa
Gas Consumption	40 MJ/h	40MJ/h	32 MJ/h
Main Injector	3.00 mm	1.80 mm	1.61 mm
Pilot Orifice (marking)	Adjustable Orifice (35)	Adjustable Orifice (35)	Adjustable Orifice (30)
Pilot Adjustment	3/4 turn out from fully in	Fully in	Fully in
Low Flame Adjustment	3 turns out from fully in	3 turns out from fully in	3 turns out from fully in
Venturi Interrupter Screw Length	30mm	30mm	15mm

NOTES:

1. When checking gas pressure, ensure that all other equipment on the same line is turned "ON".
2. Values shown are those measured at the manifold pressure test point.

INSTALLATION



THIS EQUIPMENT MUST BE INSTALLED BY AN AUTHORIZED PERSON IN ACCORDANCE WITH AS/NZS 5601.1, LOCAL AUTHORITY, GAS, ELECTRICITY, ANY APPLICABLE STATUTORY REGULATIONS AND MANUFACTURER REQUIREMENTS.

Note: Installation is the responsibility of the owner.

WATER INLET CONNECTION

1/2" BSP Male

GAS INLET CONNECTION

1/2" BSP Female.

GAS CONNECTION POINT

The gas connection point is located lower at the rear of the appliance.

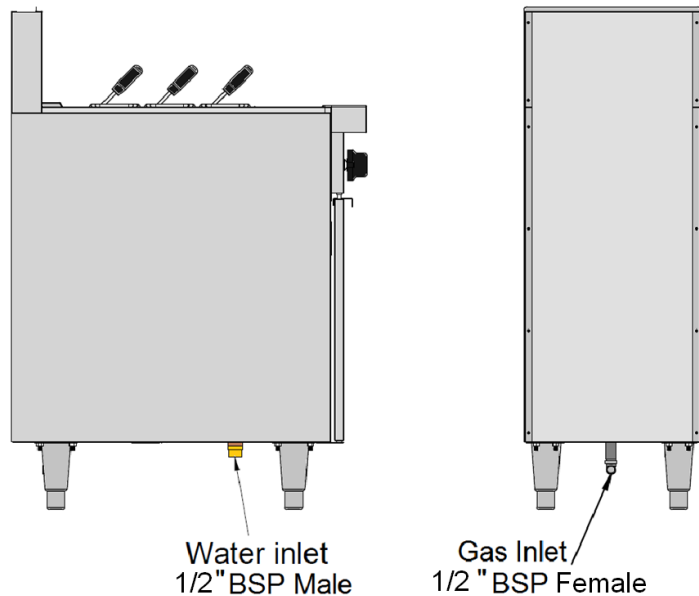

GAS CONNECTION

The appliance must be connected by an authorised person to the gas type specified on the unit. The gas type is shown adjacent to the rear gas connection point and on the data plate. Only connect to and use the specified gas type that the appliance has been set for.

Do not remove or modify any of the gas piping within the appliance. The gas connection must be made at the connection point provided.

Removal or modification of the gas piping within the appliance will void the gas certification & manufacturer's warranty. This may also affect the customer's insurance policy.

The authorised person installing this equipment must comply with AS/NZS 5601.1 requirements. Prescribed requirements include, commission the equipment, gas leakage testing, operational checking and adjustments.

All units are tested and adjusted at the factory; however, burners and pilots must be checked at the installed location and adjusted if necessary.

INSTALLATION CLEARANCES

The MINIMUM clearance from combustible surfaces is 150 mm rear and 150mm on either side. Where castors are used on installations where combustions are adjacent, ensure that a stand off isolated behind the appliance to ensure that the customer can reposition the closer than 150mm.

See diagram below.

Minimum clearance from combustible surfaces and walls

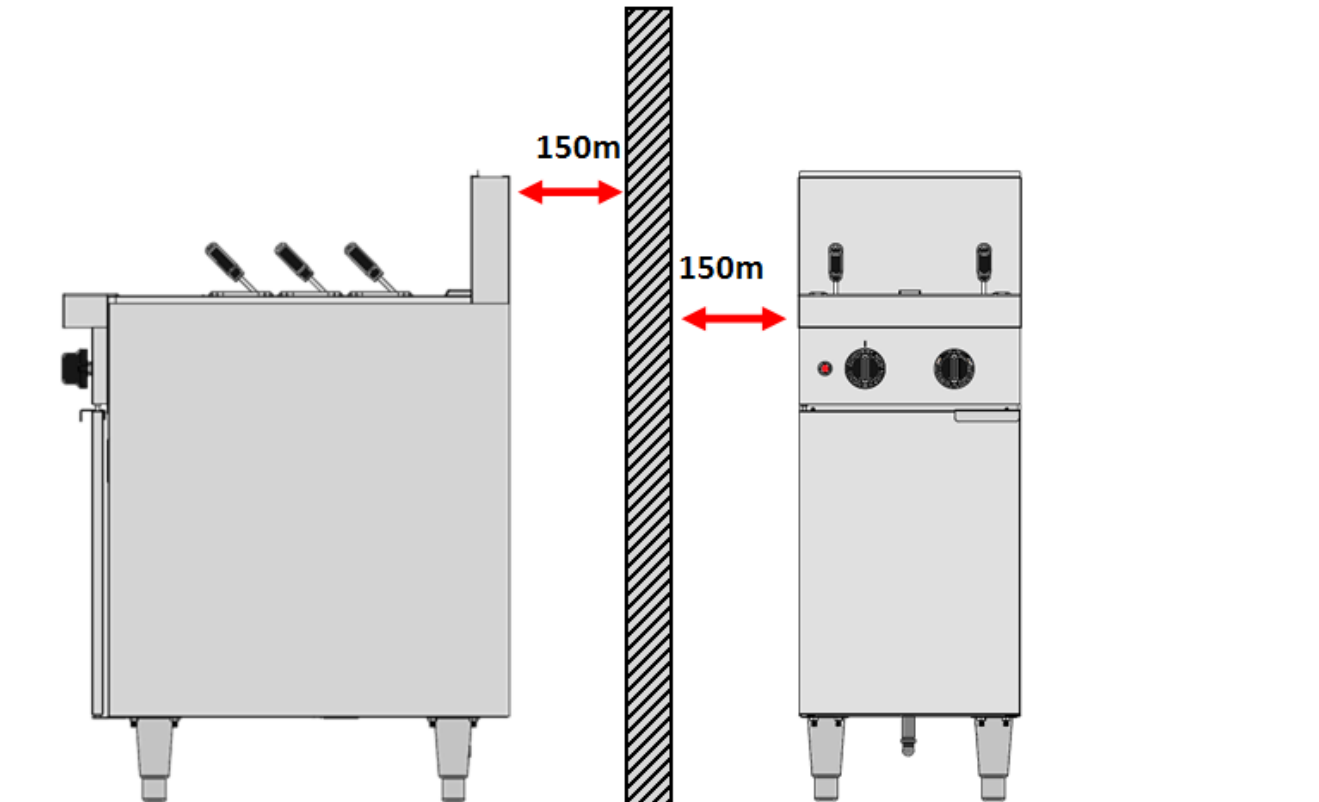

NOTE:

1. Ensure adequate clearance is provided for service & maintenance.
2. Ensure that the gas regulator is accessible for adjustment

LEVELLING

To adjust the legs to level the unit to the floor and/or to slightly adjust the height of the unit, raise the front of the unit and adjust the legs (ensure safe work practices). Similarly, raise the back and adjust the legs.

Castors are non-adjustable and should only be used when are floors level.

DO NOT LAY THE UNIT ON ITS BACK. ENSURE THE UNIT IS LEVELLED.

COMMISSIONING

LEAK TEST

- Ensure that the valve is in the OFF position.
- Turn on the main gas supply valve.
- Light all pilots.
- Leak test the valve and fittings using approved methods.
- Correct any leaks as required and re-check.
- Shut off the gas valve

	<p>WARNING: IF YOU ARE NOT COMPETENT IN PERFORMING ANY SERVICE TASK OR REQUIRE ASSISTANCE, PLEASE CONTACT: COMCATER SERVICE</p>
---	--

TEST POINT PRESSURE

The test point is located on the gas manifold behind the control panel. The test point pressure is shown on the appliance data plate and in the Gas Configuration Table.

LOW FLAME ADJUSTMENT

The low flame adjustment screw is located on each gas valve adjacent to the control shaft. Low flame adjustment setting is shown in the Gas Configuration Table on Page 8.

GAS CONTROLS—BEHIND CONTROL PANEL

PRIMARY AIR SETTING

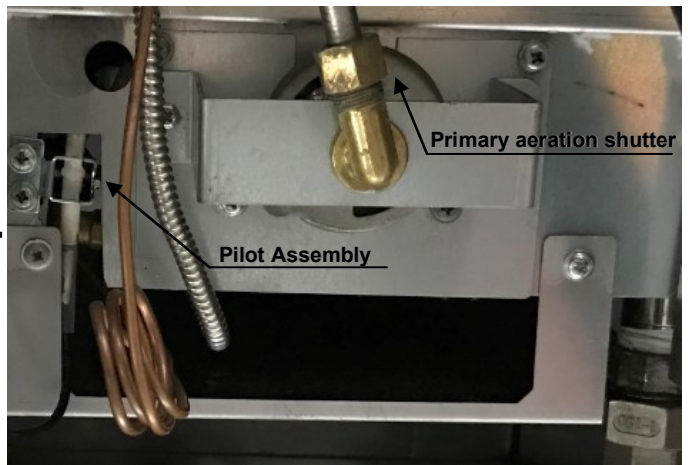
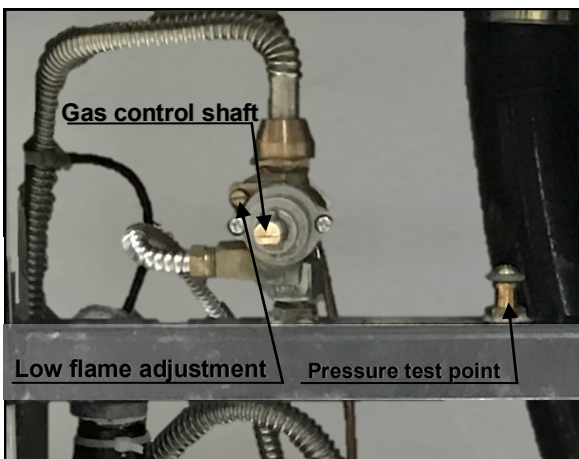

The Primary Aeration shutter setting is gas type specific. When converting between gas types ensure that the correct Primary Aeration setting and interrupter screw are used per the diagram below.

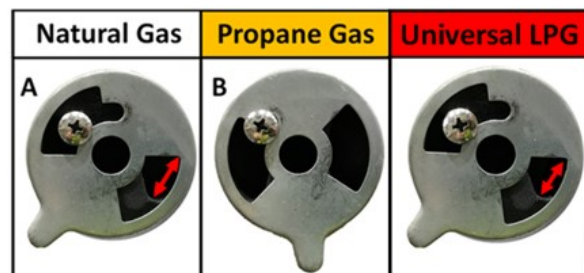

Gas Type	Drawing Reference	Aeration Shutter Setting
Natural Gas	A	25 mm
Propane Gas	B	Fully Open
Universal LPG	C	23 mm



GAS CONVERSIONS





	ONLY TO BE COMPLETED BY AN AUTHORISED PERSON
	ENSURE GAS IS ISOLATED WHILST PERFORMING CONVERSION WORK.
	PERFORM A LEAK TEST BEFORE IGNITING AND CALIBRATING BURNER AND PILOT ADJUSTEMENTS.

The RCP4 Pasta Cooker can be configured to operate on either Natural Gas or Propane Gas. If a Gas Conversion is required, Gas conversation kits are available through Comcater Spare Parts for either gas type. Detailed conversion Instructions are provided with the Gas Conversion kits.

RCP4 GAS CONVERSION KIT PART NUMBERS

MODEL	NATURAL GAS	PROPANE GAS	UNIVERSAL LPG
RCP4	THSP-RCP4-GCKIT-NG	THSP-RCP4-GCKIT-LP	RCP4-GCKIT-ULP

CONTENTS

IMAGE	DESCRIPTION
	RCP GAS CONVERSION INSTRUCTIONS
	BURNER INJECTOR
	SPRING FOR GAS REGULATOR
	GAS TYPE LABEL FOR REAR OF APPLIANCE
	GAS TYPE LABEL FOR DATA PLATE

NOTE: To arrange a Gas Conversion contact Comcater Service 1800 810 161

OPERATION



FIRST TIME USE

Before lighting the equipment for the first time, ensure that all package materials including the stainless steel protective film have been removed before lighting.

Use warm soapy water and a cloth to wipe down and remove any dust or metal filings that may have settled during manufacturing.

CORRECT ASSEMBLY

Before first time use, carefully inspect the unit to ensure that nothing has moved or has been damaged during transport. If there are any concerns please contact Comcater Technical Support 1800 810 161.

FILLING THE TANK

Before filling, ensure that the drain is in the closed position and only operate the pasta cooker when the water level is at or above the minimum water level indicator on the rear of the tank (see diagram below). Never leave the pilot light on when the tank is not filled with water. To fill the tank turn the right knob counter clockwise. Once filled turn the knob clockwise to stop the flow of water.

Filling the tank with water.

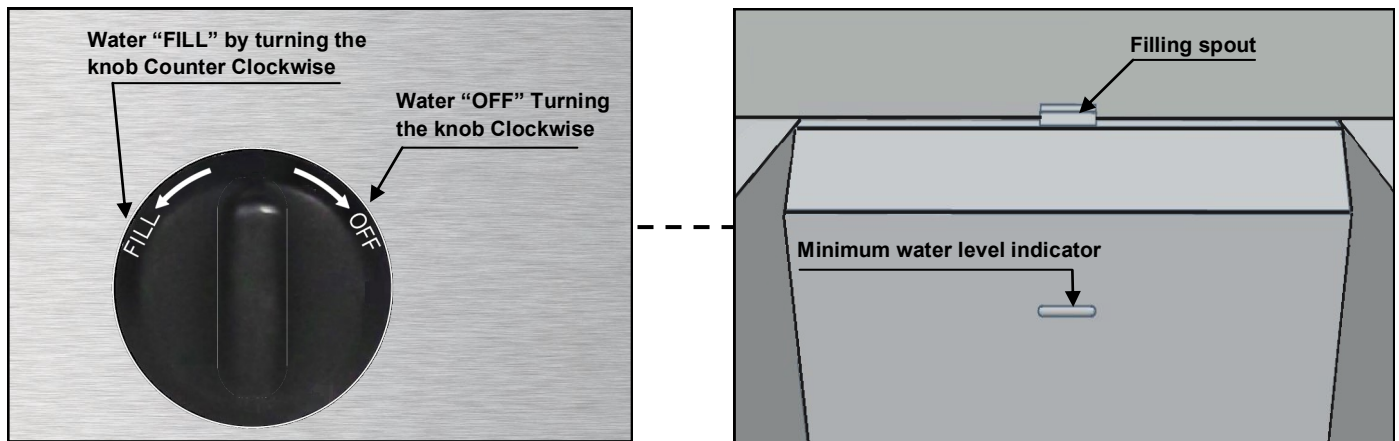

LIGHTING INSTRUCTIONS

1. Turn the Control knob from position "off" ● to "Pilot" ★.
2. Depress control knob and hold it down and light pilot immediately with "piezo ignitor".
Note: The pilot can be seen through the "pilot viewing hole".
3. Once the pilot has lit, continue to hold in the control knob for 10 seconds, before slowly releasing. (Verify that the pilot is still lit once the control knob has been released, if not repeat step 3 & 4).
4. Turn gas control knob to the "Hi-flame" 🔥 position, the burner will then ignite.
5. If the pilot becomes extinguished, repeat the above procedure.

SHUTDOWN INSTRUCTIONS

1. Turn the gas control knob to the "off" ● position.
2. Allow the equipment to cool down before cleaning.

DIAGRAM - OPERATOR CONTROLS

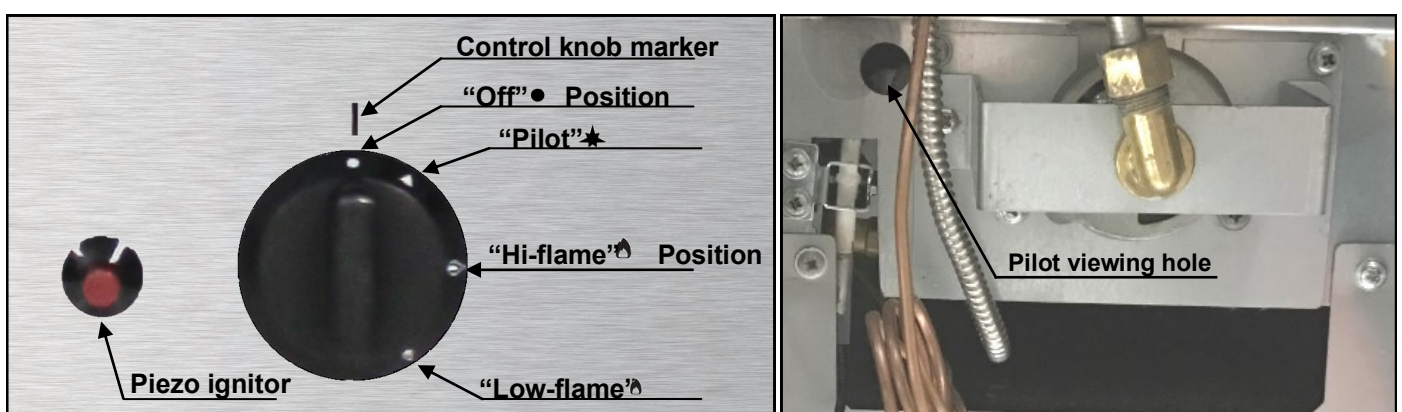

OPERATION / MAINTENANCE



DAILY OPEATION

Once the tank has been filled above the minimum water level, the pilot has been lit and the burner is switched on, the water in the tank will begin to heat.

It will take between 30 minutes to 1 hour for the water to achieve a rolling boil, depending on the incoming water temperature.

The pasta cooker has the ability to skim starch from the tank when the tank is full and the filling tap is opened to a trickle.

This will flush excess starch from the surface of the water, down the skim drain located on the apron at the front of the tank.

NOTE: Using the trickle feature may hinder the rolling boil.

If a rolling boil is required for a particular cooking process, it is recommended that this feature isn't used during cooking. Instead, use the trickle feature to flush excess starch in intervals between cooking.

Always ensure that the water within the tank does not reduce below the minimum water level marker and never dry fire the tank, and never leave the pilot lit with the tank empty.

	<p>USE ONLY SUITABLE CHEMICALS AND OBSERVE ALL MANUFACTURER SAFETY REQUIREMENTS FOR SAFE HANDLING AND USE.</p>
--	---

DAILY CLEANING

CLEANING STAINLESS STEEL

Regularly wipe the surface with hot water and detergent. Rinse and wipe the washed area with a wet sponge and clean water and wipe the area dry to prevent streaking. Follow this process and wash a small area at a time to prevent chemical residue and streaking.

Stainless steel may discolour if overheated. These stains can usually be removed using an appropriate powder or paste. Use only wood or plastic tools as necessary.

NOTES:

1. Never use steel wool to clean stainless steel.
2. Damage may occur if chemicals not suitable for stainless steel are used.

MAINTAINING A CLEAN TANK

During the cooking process pasta releases starch into the water, most of starch is flushed down the skim drain or the main drain when the tank is flushed, however deposits do accumulate on the walls of the tank. Its important to maintain the cleanliness of tank to ensure satisfactory food safety and optimum thermal efficiency of the pasta cooker.

Neglecting the cleanliness of the tank will reduce the thermal efficiency which will impact on the pasta cookers overall performance.



Long term affects of poor cleaning can result in damage or failure of the tank.

CLEANING THE TANK

Clean the tank daily with mild detergent and hot water.

Only a non-abrasive brush or cloth. Never use steel wool or abrasive scrubbing pads.

MAINTENANCE

	FOR YOUR SAFETY, ALL SERVICE WORK MUST BE CARRIED OUT BY AN AUTHORISED PERSON AND USE ONLY ORIGINAL SUPPLIED AND SPECIFIED PARTS.
	TEST ALL FITTINGS, PIPES AND PIPE CONNECTIONS FOR LEAKS IN ACCORDANCE WITH APPROVED GAS LEAK TEST PROCESSES AND METHODS. DO NOT USE A FLAME.

RECOMMENDED SERVICE PLAN

It is recommended that your appliance be serviced by an authorised person every 12 months. This period is for guidance purpose only and may vary based on usage of the equipment and operator care.

Prescribed service tasks include:

- Functional test of all components, clean and adjusted as necessary
- Inspect and clean all gas valves and lubricate with an industry approved lubricant
- Inspect all gas piping
- Check and adjust specified gas pressures
- Leak test
- Full operation, performance and safety test

For all technical queries, please contact Comcater's Technical Support Team.

Technical Phone Support

Phone: 1800 810 161

Email: techsupport@comcater.com.au

TROUBLESHOOTING

Problem	Probable Causes	Corrective Action
Burner will not light	Pilot is not lit	Light the pilot as per instructions shown on the inside of the door or on Page 14 of this manual
	Gas Control is set to "Pilot" ★	Once a pilot has been established, ensure that the gas control dial is set to "Hi-Flame" 🔥 .
	No gas supplied to unit	Verify that the gas line is connected, ensure all manual or automatic shutoff valves are open, including emergency gas shut-offs. Note: some exhaust systems have a gas supply interlock fitted, that will disrupted gas supply to the equipment if the exhaust hood isn't operating.
Pilot will not light	Pilot injector has a blockage or Gas pressure is too low	When the pilot is lit, the flame is too small to activate the thermocouple and hold the pilot on. The repair is beyond the scope of the operator, please call Comcater service to organise a technician.
	Pilot lights, but will not stay lit	When the pilot is lit, the flame is good, but the pilot won't stay lit, or drops out during service. The repair is beyond the scope of the operator, please call Comcater service to organise a technician.

For all technical queries regarding troubleshooting please contact Comcater Technical Support:
Phone: 1800 810 161 **Email:** techsupport@comcater.com.au



www.comcater.com.au/trueheat

